

SAN JUAN 1 SNJ

SAN JUAN 1

HEAVY APPLICATIONS

MOUNT: STRAIGHT (S)

MOUNT MATERIAL: BRASS (BR)

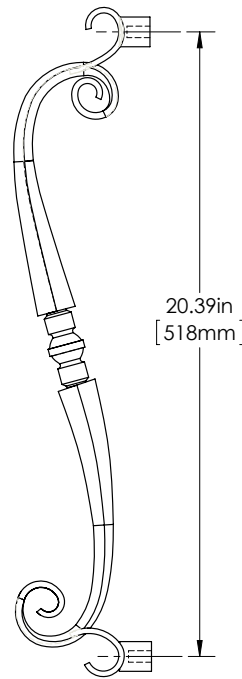
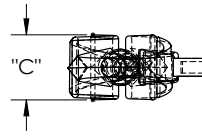
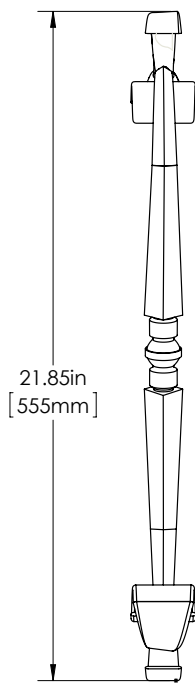

Product Description:

2 1/8" Solid Scroll Grip with Integrated Mounts in Brass

Material:

Brass

Finish Description:

US11, AGB Aged Brass; US5, ATB Antique Brass; US3, PLB Polished Brass; US4, SNB Satin Brass; US10B, ORB Oil Rubbed Bronze; US26, PLC Polished Chrome; US26D, SNC Satin Chrome; US14, PLN Polished Nickel; US15, SNN Satin Nickel; US19, MBK Matte Black PC; US10B, LTH Lithonia PC

Overall Length	Center To Center	Overall Diameter
21 1/2"(546mm)	20 1/2"(521mm)	2 1/8"(54mm)

Custom sizes & finishes available upon request.

Dimensions are approximate and provided for reference purposes only

SAN JUAN 2 SNJ

SAN JUAN 2

750 SERIES (LIGHT APPLICATIONS)

GRIP: FORGED (FRD)

MOUNT: STRAIGHT (S)

MOUNT MATERIAL: STEEL (ST)

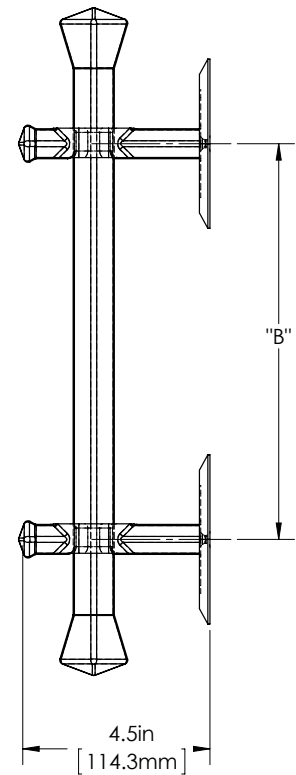
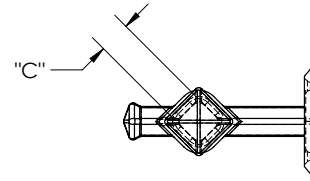
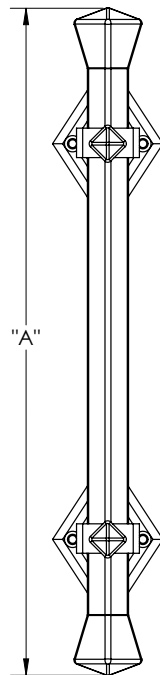

Product Description:

3/4" Solid Square Hand Forged Grip and Straight Mounts and Decorative Diamond Rosettes in Steel

Material:

Steel

Finish Description:

US19, MBK Matte Black PC; US10B, LTH Lithonia PC

Overall Length "A"	Center To Center "B"	Overall Diameter "C"
15 3/4"(400mm)	9 11/16"(246mm)	3/4"(19mm)

Custom sizes & finishes available upon request.

Dimensions are approximate and provided for reference purposes only

SAN JUAN 3 SNJ

SAN JUAN 3

750 SERIES (LIGHT APPLICATIONS)

GRIP: TWISTED (TWD)

MOUNT: STRAIGHT (S)

MOUNT MATERIAL: STEEL (ST)

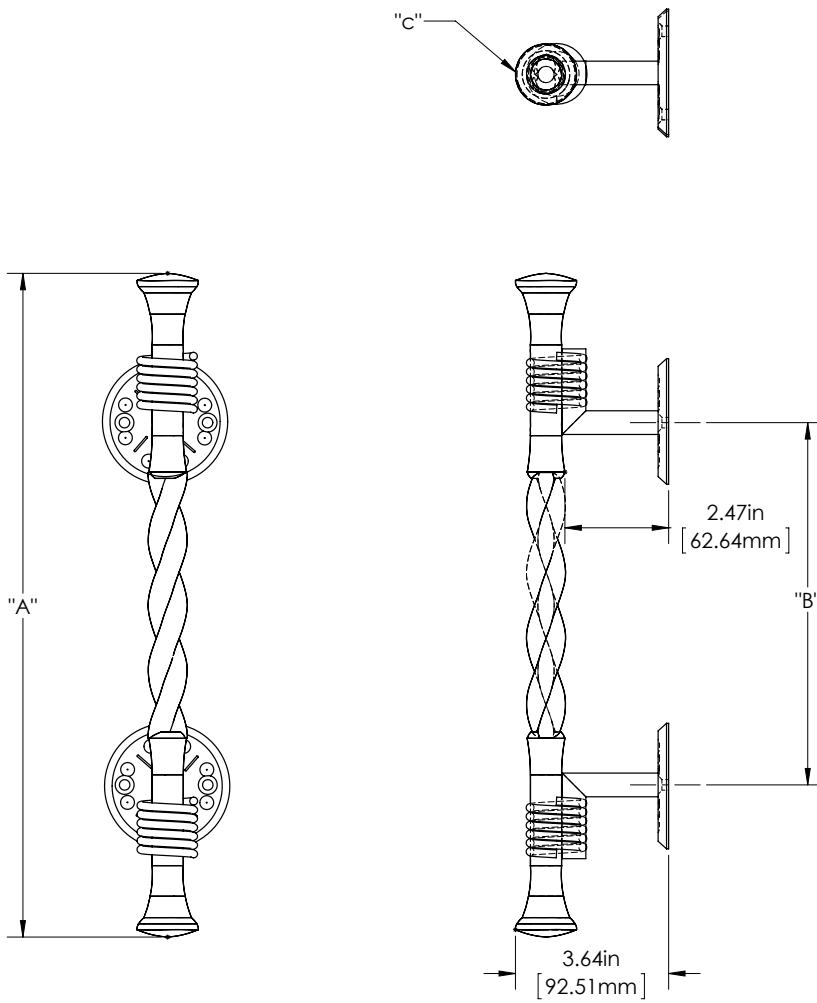

Product Description:

3/4" Solid Round Hand Forged Grip with Twisted Center, Coil Rings, Straight Mounts and Decorative Rosettes in Steel

Material:

Steel

Finish Description:

US19, MBK Matte Black PC; US10B, LTH Lithonia PC

Overall Length "A"	Center To Center "B"	Overall Diameter "C"
15"(381mm)	8 11/16"(221mm)	5/8"(16mm)

Custom sizes & finishes available upon request.

Dimensions are approximate and provided for reference purposes only

SAN JUAN 4 SJN

SAN JUAN 4

HEAVY APPLICATIONS

GRIP: HAMMERED (HRM)

MOUNT: STRAIGHT (S)

MOUNT MATERIAL: STEEL (ST)

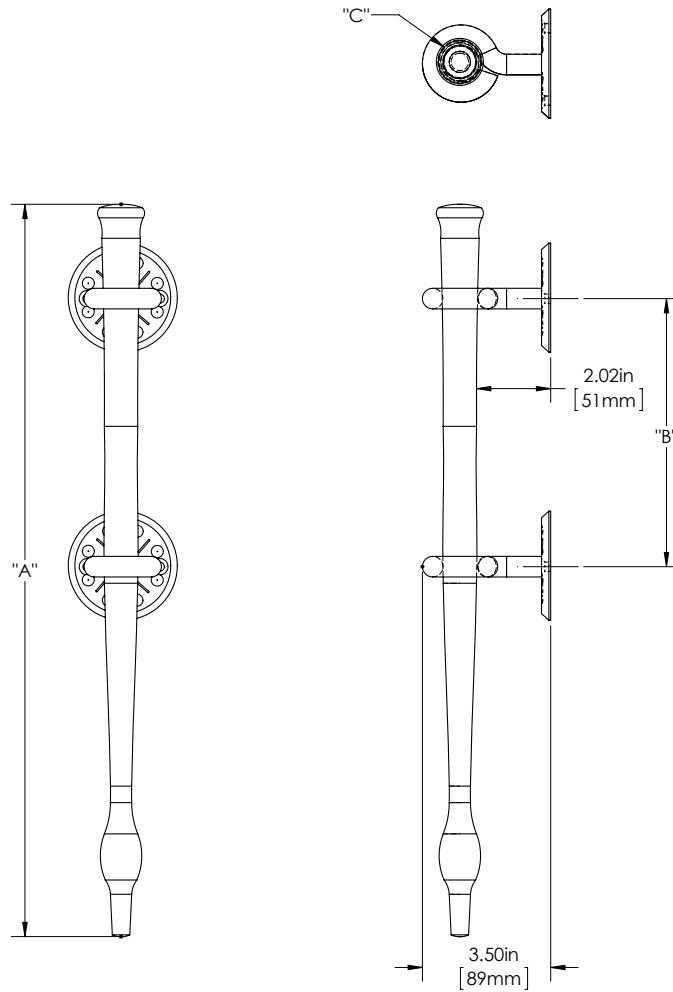

Product Description:

1 3/16" Solid Hand Forged Hammered Grip, Eyelet Mounts and Decorative Rosettes

W

Material:

Steel

Finish Description:

US19, MBK Matte Black PC; US10B, LTH Lithonia PC

Custom sizes & finishes available upon request.

Overall Length "A"	Center To Center "B"	Overall Diameter "C"
20"(508mm)	7 7/8"(200mm)	1 3/16"(30mm)

Dimensions are approximate and provided for reference purposes only

SAN JUAN 5 SJN

SAN JUAN 5

HEAVY APPLICATIONS

GRIP: FORGED (FRD)

MOUNT: STRAIGHT (S)

MOUNT MATERIAL: STEEL (ST)

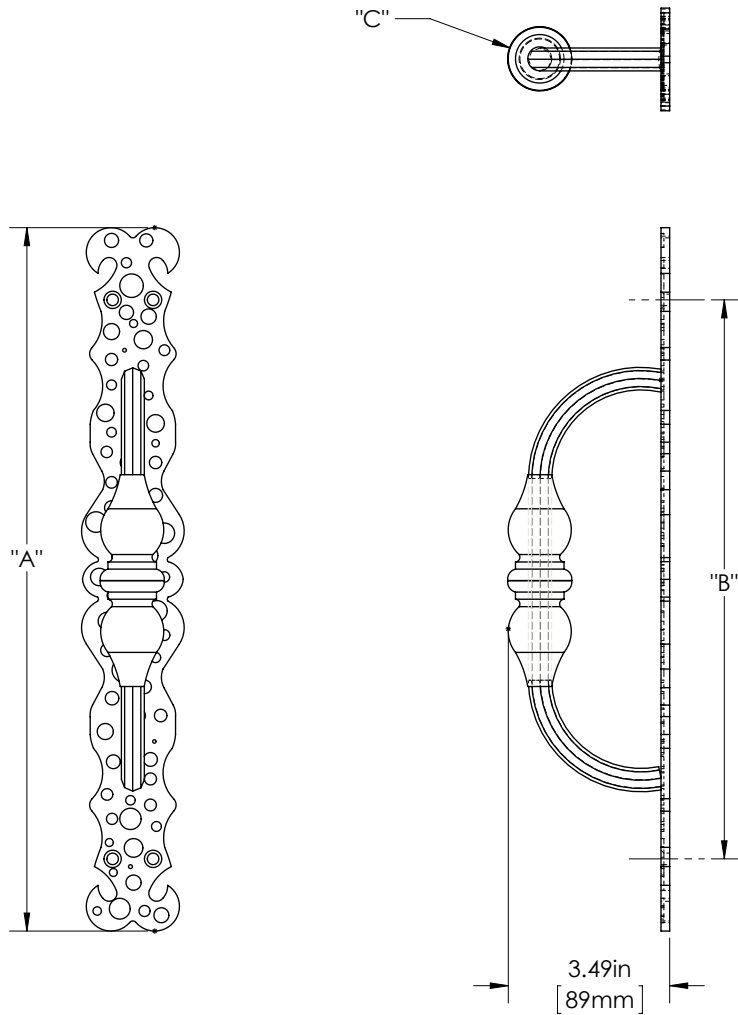

Product Description:

2 3/8" Solid Hand Forged Grip on a Decorative Backplate in Steel

Material:

Steel

Finish Description:

US19, MBK Matte Black PC; US10B, LTH Lithonia PC

Custom sizes & finishes available upon request.

Overall Length "A"	Center To Center "B"	Overall Diameter "C"
14"(355mm)	13"(330mm)	2 3/8"(60mm)

Dimensions are approximate and provided for reference purposes only